



**Dit pdf bestand bevat alle beschikbare talen van het opgevraagde document.**

**Ce fichier pdf reprend toutes langues disponibles du document demandé.**

**This pdf file contains all available languages of the requested document.**

**Dieses PDF-Dokument enthält alle vorhandenen Sprachen des angefragten Dokumentes.**

COPRO vzw - Onpartijdige instelling voor de controle van bouwproducten  
COPRO asbl - Organisme impartial de contrôle de produits pour la construction  
COPRO - A not-for-profit impartial product control body for the construction industry

Z.1. Researchpark - Kranenberg 190 - BE-1731 Zellik (Asse)  
T +32 (0)2 468 00 95 - [info@copro.eu](mailto:info@copro.eu) - [www.copro.eu](http://www.copro.eu)

KBC IBAN BE20 4264 0798 0156 - BIC KREDBEBB - BTW/TVA/VAT BE 0424.377.275 - RPR Brussel/RPM Bruxelles/RLP Brussels



**TECHNICAL PRESCRIPTIONS**  
FOR  
**VITRIFIED CLAY PIPE SYSTEMS FOR DRAINS  
AND SEWERS**  
**Part 4 : Requirements for adaptors, connectors  
and flexible couplings**

© COPRO Version 2.4 dated 2023-06-06

**COPRO** - A not-for-profit impartial product control body for the construction industry

Z.1 Research Park  
Kranenberg 190  
BE-1731 Zellik (Asse)

T. +32 (0)2 468 00 95  
info@copro.eu  
www.copro.eu

VAT BE 0424.377.275  
KBC BE20 4264 0798 0156  
RLP Brussels

**CONTENTS**

FOREWORD ..... 3

1 INTRODUCTION..... 4

    1.1 TERMINOLOGY ..... 4

    1.2 AVAILABILITY OF THIS PTV ..... 5

    1.3 STATUS OF THIS PTV ..... 6

    1.4 HIERARCHY OF RULES AND REFERENCE DOCUMENTS ..... 6

    1.5 QUESTIONS AND COMMENTS ..... 6

2 POSITIONING OF TECHNICAL PRESCRIPTIONS ..... 7

    2.1 PTV FORMAT ..... 7

    2.2 OBJECTIVES..... 7

    2.3 SCOPE ..... 7

    2.4 REFERENCE DOCUMENTS ..... 8

3 PRESCRIPTIONS ..... 9

    3.1 PRODUCTION UNIT AND EQUIPMENT ..... 9

    3.2 RAW MATERIALS, JOINT MATERIALS AND COUPLING MATERIALS..... 9

    3.3 PRODUCTION PROCESS ..... 12

    3.4 ADAPTORS AND CONNECTORS OF VITRIFIED CLAY ..... 12

    3.5 JOINT ASSEMBLIES ..... 14

    3.6 TYPE TESTING ..... 17

4 TEST METHODS ..... 18

    4.1 SAMPLING..... 18

    4.2 SAMPLE PREPARATION ..... 18

    4.3 HIGH CHEMICAL RESISTANCE OF SOFT CAST POLYURETHANE ..... 18

    4.4 WATERTIGHTNESS OF AN ASSEMBLY OF AN INSERTABLE CONNECTOR AND A CLAY PIPE ..... 21

5 PRODUCT IDENTIFICATION ..... 23

    5.1 PRODUCT NAME ..... 23

    5.2 IDENTIFICATION..... 23

6 APPLICATION OF THE PRODUCT (informative)..... 25

    6.1 APPLICATION OF THE PRODUCT ..... 25

## FOREWORD

This document contains the technical requirements for adaptors, connectors and flexible couplings for vitrified clay pipe systems for drains and sewers. The requirements included in these PTV respond to needs established by the various interested parties according to local customs.

The conformity of pipes and joints can be certified under the voluntary BENOR mark. With the BENOR mark, the supplier has to declare the performance of adaptors, connectors and flexible couplings for all the characteristics relevant to guaranteeing the application and limit values imposed by this PTV 895-4.

BENOR certification is based on full product certification in accordance with EN ISO/IEC 17067.

The CE mark applies to pipes and joints for pipe jacking for vitrified clay pipe systems for drains and sewers, coming under the area of application of EN 295-4. Pursuant to European Regulation (EU) no. 305/2011 (Construction Product Regulation – CPR) dated 2011-03-09, the CE mark relates to the essential characteristics of the product specified in EN 295-4, Annex ZA, Table ZA.1.

The CE mark is the only mark to declare that the product complies with the declared performance of the essential characteristics covered by EN 295-4.

# 1 INTRODUCTION

## 1.1 TERMINOLOGY

### 1.1.1 Definitions

Article	Set of units of a product with the same characteristics and performance that are produced in a specific manner and comply with the technical file.
Supplier	The party having to ensure that the product complies with the technical requirements. This definition can apply to the producer, the dealer, the importer or the distributor.
Impartial body	Body that is independent of the supplier or user and is entrusted with conducting the acceptance test on delivery.
Joints	Component used in an assembly of a vitrified clay product with another (vitrified clay) product
Producer	The party responsible for producing the product.
Product	The result of an industrial activity or process. Meant by this in the context of these technical requirements is the product. It is the collective term for all articles and product types to which this PTV applies.
Product unit	An individual produced item. Different product units can form an article.
Production unit	Technical facility/facilities tied to a geographical location used by a producer and in which one or more products are made.
Test	Technical action comprising the determination of one or more properties of a raw material or product according to a specified process.
Reference document	Document specifying the technical characteristics with which the materials, equipment, raw materials, production process and/or the product must comply (a standard, specification or any other technical specification).

All definitions described in EN 295-4; Clause 3 are also valid in this PTV.

### 1.1.2 Abbreviations

PTV            Technical Prescriptions

All symbols and abbreviations described in EN 295-4, Clause 4 are also valid in this PTV.

### 1.1.3 References

CPR	Construction Product Regulation
EN 10088-2	Stainless steels – Part 2: Technical delivery conditions for sheet/plate and strip of corrosion resisting steels for general purposes
EN 295-3	Vitrified clay pipe systems for drains and sewers – Part 3: Test methods
EN 295-4	Vitrified clay pipe systems for drains and sewers – Part 4: Requirements for adaptors, connectors and flexible couplings
EN 681-4	Elastomeric seals - Materials requirements for pipe joint seals used in water and drainage applications - Part 4: Cast polyurethane sealing elements
EN ISO/IEC 17067	Conformity assessment - Fundamentals of product certification and guidelines for product certification schemes
PTV 895-1	Technical prescriptions for vitrified clay pipe systems for drains and sewers – Part 1: Requirements for pipes, fittings and joints
PTV 895-6	Technical prescriptions for vitrified clay pipe systems for drains and sewers – Part 6: Requirements for components of manholes and inspection chamber
PTV 895-7	Technical prescriptions for vitrified clay pipe systems for drains and sewers – Part 7: Requirements for pipes and joints for pipe jacking
PTV 832-1	Technical prescriptions for elastomeric seals: Part 1: Vulcanized Rubber

This PTV contains dated and undated references. Only the cited version applies to dated references. The latest version always applies to undated references, including any errata, addenda and amendments.

Of all the EN standards referred to in these prescriptions, the corresponding Belgian publication NBN EN applies in each case. COPRO can allow the use of a publication other than the Belgian one provided its content is identical to that of the Belgian publication.

## 1.2 AVAILABILITY OF THIS PTV

The current version of this PTV is available free of charge on the COPRO website.

A paper version of this PTV can be ordered from COPRO. COPRO has the right to charge for this.

No changes may be made to the original PTV approved by the sectoral commission and/or confirmed by the Governing body of COPRO.

## **1.3 STATUS OF THIS PTV**

### **1.3.1 Version of this PTV**

This PTV concerns version 3.0 and replaces version 2.0.

### **1.3.2 Approval of this PTV**

This PTV was approved by the sectoral commission on 2023-06-20.

### **1.3.3 Confirmation of this PTV**

This PTV was confirmed by the Board of Directors of COPRO on 2023-09-18.

### **1.3.4 Registration of this PTV**

This PTV was submitted to the association BENOR on 2023-09-19.

## **1.4 HIERARCHY OF RULES AND REFERENCE DOCUMENTS**

### **1.4.1 Legislation**

If certain rules contained in this PTV are inconsistent with applicable law, the rules arising from the legislation shall prevail. It is the responsibility of the supplier to monitor this and report any contradictions to COPRO in advance.

### **1.4.2 Directives concerning health and safety**

If certain technical prescriptions are inconsistent with the directives concerning health and safety, such directives shall prevail. It is the responsibility of the supplier to monitor this and report any contradictions to COPRO in advance.

### **1.4.3 Special specification**

If certain rules from the applicable special specification are inconsistent with these technical prescriptions, the supplier can report this to COPRO.

## **1.5 QUESTIONS AND COMMENTS**

Questions or comments concerning these technical prescriptions are directed to COPRO.

## 2 POSITIONING OF TECHNICAL PRESCRIPTIONS

### 2.1 PTV FORMAT

#### 2.1.1 Format of this PTV

These technical prescriptions for the adaptors, connectors and flexible couplings for vitrified clay pipe systems for drains and sewers are drawn up by the Sectoral Commission for clay products of COPRO.

### 2.2 OBJECTIVES

#### 2.2.1 Purpose of this PTV

- 2.2.1.1 The aim of this PTV is to specify requirements for the adaptors, connectors and flexible couplings used for vitrified clay pipe systems for drains and sewers.
- 2.2.1.2 According to the legislation in the Member State where adaptors, connectors and flexible couplings for vitrified clay pipe systems for drains and sewers are brought onto the market, the performance for some essential characteristics has to be declared for the CE mark by the supplier on the basis of its Declaration of Performance in accordance with the harmonised standard EN 295-4. Unless other statutory provisions apply, the supplier has the choice in the context of the CE mark to declare no performance for one or more essential characteristics. This PTV clarifies some requirements and adds supplementary provisions with regard to use and sustainable behaviour.

### 2.3 SCOPE

#### 2.3.1 Subject of these technical prescriptions

- 2.3.1.1 The subject of these technical prescriptions is the same as the scope in EN 295-4, Clause 1.
- 2.3.1.2 The area of application of this PTV is entirely or partially covered by the intended use included in the harmonised standard EN 295-4. This PTV imposes additional application requirements.

The requirements included in this PTV for the adaptors, connectors and flexible couplings for the buried drain and sewer systems for the conveyance of wastewater (including domestic wastewater, surface water and rainwater) under gravity and periodic hydraulic surcharge or under continuous low head of pressure, respond to needs determined by the various interested parties according to local construction technologies and customs.



---

### **2.3.2 Circulars**

COPRO can supplement this PTV with one or more circulars forming an integral part of this PTV.

---

## **2.4 REFERENCE DOCUMENTS**

---

### **2.4.1 Product standards**

The applicable product standard is EN 295-4.

---

### **2.4.2 Tender documents**

The applicable tender documents are SB 250, CCT Qualiroutes, TB 2015 and special tender documents.

---

### **2.4.3 Test methods**

The applicable test methods are prescribed in EN 295-3 and Clause 4 of this PTV.

---

### **2.4.4 Other**

Other applicable reference documents are mentioned in Clause 1.1.3.

## **3 PRESCRIPTIONS**

### **3.1 PRODUCTION UNIT AND EQUIPMENT**

#### **3.1.1 Production unit**

3.1.1.1 The production unit meets the requirements of the applicable reference documents.

The production unit (in its entirety and all its parts) is presumed to comply with all the applicable laws concerning the environments, operation, economic, et cetera.

#### **3.1.2 Production equipment**

The supplier has equipment suitable for production according to the reference documents.

### **3.2 RAW MATERIALS, JOINT MATERIALS AND COUPLING MATERIALS**

#### **3.2.1 General**

3.2.1.1 The materials shall be free of any substances which may have a deleterious effect on the fluid being conveyed, or on the life of the seal, or on the adaptors and connectors.

#### **3.2.2 Clay**

3.2.2.1 Adaptors and connectors shall be made from suitable natural clays to enable the body to be fired to vitrification, so that the final product is in accordance with EN 295-4.

#### **3.2.3 Vulcanized rubber sealing elements**

3.2.3.1 To be considered as a vulcanized rubber sealing element, suitable for the use in combination with adaptors and connectors according this PTV, the rubber sealing element shall comply with PTV 832-1, including Clause 3.4.18.

#### **3.2.4 Hard cast polyurethane sealing elements**

3.2.4.1 To be considered as a hard cast polyurethane sealing element, suitable for the use in the socket of pipes according this PTV, the polyurethane sealing element shall comply with EN 295-1, Clause 6.1.4.

### 3.2.5 Soft cast polyurethane sealing elements

3.2.5.1 To be considered as a cast polyurethane sealing element, suitable for the use in adaptors and connectors according this PTV, the polyurethane sealing element shall meet the requirements set out in Clauses 3.2.4.2 to 3.2.4.9.

#### 3.2.5.2 Dimensional tolerances

See EN 681-4, Clause 4.2.1.

#### 3.2.5.3 Imperfections and defects

See EN 681-4, Clause 4.2.2.

#### 3.2.5.4 Hardness

See EN 681-4, Clause 4.2.3.

Shore A hardness measurements shall be used instead of IRHD.

#### 3.2.5.5 Tensile strength and elongation at break

See EN 681-4, Clause 4.2.4.

#### 3.2.5.6 Compression set in air

See EN 681-4, Clause 4.2.5.

#### 3.2.5.7 Accelerated ageing in air

See EN 681-4, Clause 4.2.6.

#### 3.2.5.8 Stress relaxation in compression

See EN 681-4, Clause 4.2.7.

#### 3.2.5.9 High chemical resistance

High chemical resistance shall not be greater than the values given in table 1.

**Table 1: High chemical resistance**

Property	Unit	Requirement
$\Delta V_7$	%	$\leq 5$
$\Delta \text{Shore A}_7$	Shore A	$\leq 10$
$\Delta \text{Shore A}_{7/7}$	Shore A	$\leq 5$

In this context is:

- $\Delta V_7$ : relative change in volume as % after depositing the test fluid for seven days at  $(23 \pm 2)$  °C.
- $\Delta \text{Shore } A_7$ : change in Shore A hardness after depositing in the test fluid for seven days at  $(23 \pm 2)$  °C.
- $\Delta \text{Shore } A_{7/7}$ : change in Shore A hardness after depositing in the test fluid for seven days at  $(23 \pm 2)$  °C and then drying out for seven days at normal temperature.

High chemical resistance is tested in accordance to clause 4.3 of this PTV.

---

### **3.2.6 Polypropylene sleeve couplings**

3.2.6.1 To be considered as a polypropylene sleeve coupling, suitable for connecting pipes according this PTV, the polypropylene sleeve coupling shall comply with EN 295-1, Clause 6.1.3.

Vulcanized rubber sealing elements used in combination with polypropylene sleeve couplings according to this PTV shall comply with Clause 3.2.3 of this PTV.

---

### **3.2.7 Metal banded flexible couplings and adaptors**

3.2.7.1 To be considered as a metal banded flexible coupling, suitable for the use in joint assemblies, they shall meet the performance requirements specified in Annex A of EN 295-4.

Vulcanized rubber elements used for metal banded flexible couplings and adaptors according to this PTV shall comply with Clause 3.2.3 of this PTV.

Stainless steel used for metal banded flexible couplings and adaptors according to this PTV shall be chosen out of the classes foreseen in Clause A.3.3.1 of EN 295-4. This class shall be declared on the technical data sheet of the article.

---

### **3.2.8 Connectors, insertable fittings and sealing rings**

3.2.8.1 To be considered as a connector, insertable fitting or sealing ring, suitable for the use in joint assemblies, they shall meet the performance requirements specified in Annex B of EN 295-4.

Vulcanized rubber sealing elements used in combination with connectors and insertable fittings according to this PTV shall comply with Clause 3.2.3 of this PTV.

Vulcanized rubber sealing elements used as a sealing ring according to this PTV shall comply with Clause 3.2.3 of this PTV.

### **3.3 PRODUCTION PROCESS**

There aren't any requirements for the production process.

### **3.4 ADAPTORS AND CONNECTORS OF VITRIFIED CLAY**

#### **3.4.1 General**

- 3.4.1.1 The adaptors and connectors made of vitrified clay shall meet the requirements set out in Clauses 3.4.2 to 3.4.10.
- 3.4.1.2 The supplier shall in each case declare the performance for the characteristics set out in Clauses 3.4.2 to 3.4.10 for the adaptors and connectors for vitrified clay pipe systems for drains and sewers. If it concerns an essential characteristic, the supplier shall declare this on its Declaration of Performance.
- 3.4.1.3 Adaptors and connectors of vitrified clay shall be sound and shall be free from such defects as would impair their function when in service.

#### **3.4.2 Water absorption**

See EN 295-1, Clause 5.1.3.

Water absorption is determined in accordance with Clause 28 of EN 295-3.

#### **3.4.3 Appearance**

See EN 295-1, Clause 5.1.4.

#### **3.4.4 Internal diameter**

See EN 295-4, Clause 5.2.

To be considered as connectors and adaptors according to this PTV used with pipes, fittings, jacking pipes, manholes or inspection chambers according to resp. PTV 895-1, PTV 895-7, PTV 895-6, their internal diameter shall be as specified in PTV 895-1, Clause 3.4.6.

#### **3.4.5 Length**

See EN 295-4, Clause 5.3.

#### **3.4.6 Angles**

See EN 295-4, Clause 5.4.

---

### **3.4.7 Squareness of ends and joint interchangeability**

See EN 295-4, Clause 5.5.

Squareness of ends is determined in accordance with Clause 5.1 of EN 295-3.

To be considered as adaptors and connectors for vitrified clay pipe systems for drains and sewers according to this PTV, the joint interchangeability shall be in accordance with PTV 895-1, Clause 3.5.5.

---

### **3.4.8 Bond strength of adhesive for fixing fired vitrified clay parts together**

See EN 295-4, Clause 5.6.

Bonding strength of adhesive used for fixing fired clay parts together is determined in accordance with Clause 10 of EN 295-3.

---

### **3.4.9 Tightness**

See EN 295-4, Clause 5.7.

Tightness is determined in accordance with Clause 12 or Clause 16 of EN 295-3. Depending whether the test is carried out using a water test or an air test. The monitoring equipment used to measure pressure loss should be accurate to within 1 mbar.

---

### **3.4.10 Chemical resistance**

See EN 295-4, Clause 5.8.

Chemical resistance is determined in accordance with Clause 13 of EN 295-3.

## **3.5 JOINT ASSEMBLIES**

### **3.5.1 General**

- 3.5.1.1 Adaptors and connectors, used in joint assemblies connecting vitrified clay pipeline systems shall meet the requirements set out in Clauses 3.5.2 to 3.5.8 and voluntary the additional requirement set out in Clause 3.5.9.
- 3.5.1.2 Adaptors and connectors, used in joint assemblies connecting vitrified clay pipelines to pipelines of other materials which do not undergo significant diametrical deflection under shear test load (e.g. concrete, cast iron, ductile iron, steel, fibre-cement) shall meet the requirements set out in Clauses 3.5.3 to 3.5.7.
- 3.5.1.3 Adaptors and connectors, used in joint assemblies connecting vitrified clay pipelines to pipelines of other materials which undergo significant diametrical deflection under shear test load (e.g. PVC-U, PE, PP) shall meet the requirements set out in Clauses 3.5.3 to 3.5.7.
- 3.5.1.4 The supplier shall in each case declare the performance for the characteristics set out in Clauses 3.5.2 to 3.5.8 for the joint assemblies of adaptors and connectors for vitrified clay pipe systems for drains and sewers. The supplier shall also declare the performance for the applicable additional characteristic set out in Clause 3.5.9 for the joint assemblies connecting vitrified clay pipeline systems. If it concerns an essential characteristic, the supplier shall declare this on its Declaration of Performance.

### **3.5.2 Joint interchangeability - dimensions**

See EN 295-1, Clause 6.4.

The jointing system according to Clause 6.4 of EN 295-1 shall be declared by the manufacturer in the technical data sheet of the article.

### **3.5.3 Watertightness under angular deflection**

See EN 295-1, Clause 6.2.2.

Watertightness of joint assemblies under deflection is determined in accordance with Clause 21.2 of EN 295-3.

The highest value of deflection for which the product conforms shall be declared on the technical data sheet.

### 3.5.4 Watertightness under shear load

See EN 295-1, Clause 6.2.3.

Watertightness of joint assemblies under shear load is determined in accordance with Clause 21.3 of EN 295-3.

For adaptors and connectors, used in joint assemblies connecting vitrified clay pipelines to pipelines of other materials which undergo significant diametrical deflection under shear test load (e.g. PVC-U, PE, PP), the exception is made that when the shear load is applied on the flexible pipe, the applied load shall be that required to produce a diametrical deflection of  $(3 \pm 0,5)$  % on the external diameter.

### 3.5.5 Chemical and physical resistance to effluent

See EN 295-1, Clause 6.5, taking into account that there will be a distinction between solutions for extreme conditions (class CH) and solutions for normal conditions (class CN), as described in table 2.

**Table 2: Test solutions for normal and extreme conditions**

Class CH	Class CN
Sulphuric acid solution c (H <sub>2</sub> SO <sub>4</sub> ) = 0.5 mol/L (pH = 0 approximately)	Sulphuric acid solution c (H <sub>2</sub> SO <sub>4</sub> ) = 0.005 mol/L (pH = 2.0 approximately)
Nitric acid solution c (HN0 <sub>3</sub> ) = 1 mol/L (pH = 0 approximately)	Nitric acid solution c (HN0 <sub>3</sub> ) = 0.01 mol/L (pH = 2.0 approximately)
Sodium hydroxide solution c (NaOH) = 1 mol/L (pH = 14 approximately)	Sodium hydroxide solution c (NaOH) = 0.01 mol/L (pH = 12.0 approximately)
Sodium hypochlorite solution c (NaOCL) = 1 mol/L stabilised with sodium hydroxide (pH = 14 approximately)	Sodium hypochlorite solution c (NaOCL) = 0.01 mol/L stabilised with sodium hydroxide (pH = 12.0 approximately)

The class is part of the identification of the product (see Clause 5.1.1) and shall be declared on the technical data sheet.

Chemical and physical resistance to effluent of joint assemblies is determined in accordance with Clause 23 of EN 295-3.



---

### **3.5.6 Thermal cycling stability**

See EN 295-1, Clause 6.6.

Thermal cycling stability of joint assemblies is determined in accordance with Clause 24.1 of EN 295-3. As an alternative to the test conditions specified in this test method, the following test conditions may also be used:

- Ambient temperature for 2h
- 4 times
  - 8h at (-10 +/- 2) °C
  - 16h at (+70 +/- 2) °C
- 8h at (-10 +/- 2) °C
- Ambient temperature for 2h

The test report must make clear which test conditions were applied.

---

### **3.5.7 Long-term thermal stability**

See EN 295-1, Clause 6.7.

Long-term thermal stability of joint assemblies is determined in accordance with Clause 24.2 of EN 295-3.

---

### **3.5.8 Increased watertightness at 1 bar**

The increased watertightness at 1 bar shall be tested in accordance with EN 295-3 Clause 21.1 without shear load or angular deflection at a pressure of 1 bar ± 0,05 bar. During the testing time of 15 minutes no visual leakage may occur.

---

### **3.5.9 Watertightness of an assembly of an insertable connector and a clay pipe**

Watertightness of an assembly of an insertable connector and a clay pipe is determined and evaluated in accordance with Clause 4.4 of this PTV.

---

### **3.5.10 Increased watertightness at 1 bar of an assembly of an insertable connector and a clay pipe**

The increased watertightness of an assembly of an insertable connector and a clay pipe at 1 bar shall be tested in accordance with EN 295-3 Clause 21.1 without shear load or angular deflection at a pressure of 1 bar ± 0,05 bar. During the testing time of 15 minutes no visual leakage may occur.

## **3.6 TYPE TESTING**

---

### **3.6.1 General**

3.6.1.1 The type test comprises laboratory validation of the characteristics.

3.6.1.2 The type test is conducted under the responsibility of the supplier.

---

### **3.6.2 Scope**

For each article there is conducted a type test.

---

### **3.6.3 Requirements**

All characteristics of Clause 3.4 and 3.5 which are applicable are determined in the type test.

For some characteristics, the manufacturer may divide the article in different families, according to the requirements foreseen in Clause 2 of EN 295-2.

---

### **3.6.4 Type test report**

The details and results of the type test are recorded in a type test report by the supplier.

---

### **3.6.5 Validity**

Type tests are valid as long as there are no modifications conducted (Clause 3.6.6).

---

### **3.6.6 Modifications**

If a raw material, the composition, the production process or other relevant parameters are adjusted, the supplier must assess the influence of this modification on the characteristics of the article or product type.

It may prove necessary in this regard to re-run part or all of the type test.

## 4 TEST METHODS

### 4.1 SAMPLING

#### 4.1.1 Sampling of soft cast polyurethane

See EN 681-4, Clause 7.1.

#### 4.1.2 Sampling of the other products

Sampling of all the other products is executed in accordance with the relevant clauses of the applicable standards.

### 4.2 SAMPLE PREPARATION

#### 4.2.1 Sample preparation of soft cast polyurethane

See EN 681-4, Clause 5.1.

#### 4.2.2 Sample preparation of the other products

Sample preparation of all the other products is executed in accordance with the relevant clauses of the applicable standards.

### 4.3 HIGH CHEMICAL RESISTANCE OF SOFT CAST POLYURETHANE

#### 4.3.1 Aim and principle

The aim of this test is to determine the resistance of the seal to environments with pH0 and pH14.

The principle of this test is to condition the sample at pH0 and pH14 for 168 hours after which change in volume and in hardness is determined.

Change in hardness will also be measured after conditioning the sample at pH0 and pH14 for 168 hours and air-drying for seven days at specific conditions.

---

### 4.3.2 Instruments

See ISO 1817, Clause 3.1 and 3.3.

See ISO 48, Clause 5.

---

### 4.3.3 Sample preparation

Test samples for the determination of change in volume shall have 1 of the following dimensions in mm:

- Cylinder (diameter x height):  $(13 \pm 0,5) \times (6,3 \pm 0,3)$ , with parallel end faces,
- Cuboid  $(11,5 \pm 0,5) \times (11,5 \pm 0,5) \times (6,3 \pm 0,3)$ .

Test samples for determination of change in hardness shall be according ISO 48, Clause 6.

---

### 4.3.4 Test temperature for soft cast polyurethane

See EN 681-4, Clause 5.2.

---

### 4.3.5 Method

#### 4.3.5.1 Determination of change in volume $\Delta V_7$

- Measure the dimensions of the test sample and calculate the volume ( $V_0$ ). The volume shall be determined at  $0,005 \text{ cm}^3$ ;
- Expose the test sample to sulphuric acid (pH level about 0) and caustic soda (pH level about 14) over 168 hours at test temperature;
- Remove the test samples out of the test fluid and measure the dimensions within 5 minutes after removal out of the test fluid. Determine the volume at  $0,005 \text{ cm}^3$  ( $V_1$ ).

#### 4.3.5.2 Determination of change in hardness $\Delta \text{Shore } A_7$

- Measure the hardness Shore A of the test sample according to method M of ISO 48 (Shore  $A_0$ ). Another method of ISO 48 can be accepted, but in case of doubt, method M shall be used as reference;
- Expose the test sample to sulphuric acid (pH level about 0) and caustic soda (pH level about 14) over 168 hours at test temperature;
- Remove the test sample out of the test fluid and measure the hardness Shore A according to ISO 48 within 5 minutes after removal out of the test fluid (Shore  $A_1$ ). The same test method of ISO 48 used before exposure to the test fluid shall be used after exposure.

#### 4.3.5.3 Determination of change in hardness $\Delta\text{Shore } A_{7/7}$ :

- Measure the hardness Shore A of the test sample according to method M of ISO 48 (Shore  $A_2$ ). Another method of ISO 48 can be accepted, but in case of doubt, method M shall be used as reference;
- Expose the test samples to sulphuric acid (pH level about 0) and caustic soda (pH level about 14) over 168 hours at test temperature;
- Remove the test samples out of the test fluid and dry them out for seven days at a standard atmosphere 23/50 class 2 according to EN ISO 291;
- Measure the hardness Shore A according to ISO 48 within 5 minutes after removal out of the drying conditions (Shore  $A_3$ ). The same test method of ISO 48 used before exposure to the test fluid shall be used after exposure drying;
- If possible, determination of hardness Shore  $A_1$  and hardness Shore  $A_3$  can be performed on the same test samples. In that case value of hardness Shore  $A_2$  can be adopted from the value of hardness Shore  $A_0$ .

---

#### 4.3.6 Result

$\Delta V_7$  is calculated as follows:  $\Delta V_7 = \text{abs} ((V_1 - V_0) / V_0) * 100 \%$ ;

$\Delta\text{Shore } A_7$  is calculated as follows:  $\text{abs} (\text{Shore } A_1 - \text{Shore } A_0)$ ;

$\Delta\text{Shore } A_{7/7}$  is calculated as follows:  $\text{abs} (\text{Shore } A_3 - \text{Shore } A_2)$ .

---

#### 4.3.7 Test report

The test report sets out at least:

- the details of the laboratory,
- the details and identification of the sample,
- a description of the packaging in which the sample was delivered (possible damage, et cetera),
- the start-date and the end-date of the test,
- $V_0$ ,  $V_1$  and  $\Delta V_7$ ,
- Shore  $A_0$ , Shore  $A_1$ , Shore  $A_2$ , Shore  $A_3$ ,  $\Delta\text{Shore } A_7$  and  $\Delta\text{Shore } A_{7/7}$ ,
- a reference to PTV 895-1, clause 3.2.4.9.

Each test report is supplemented by an assessment of conformity to the requirements.

## 4.4 WATERTIGHTNESS OF AN ASSEMBLY OF AN INSERTABLE CONNECTOR AND A CLAY PIPE

### 4.4.1 Aim and principle

This test is used to determine the suitability of a connector in an assembly with a clay pipe.

### 4.4.2 Instruments

Testing equipment, suitable for applying the load as described below. The accuracy of the testing equipment load shall be class 1 according EN ISO 7500-1.

Testing equipment, suitable for applying the water pressure as described below. The accuracy of the testing equipment pressure shall be 1 %.

### 4.4.3 Sample preparation

Install the connector according the requirements of the manufacturer in the borehole with a suitable jointing profile. Drilling the borehole must comply with the instructions from the manufacturer.

Install inside the connector a piece of a pipe wherefore the connector is designed. The ends of the piece shall be made straight and parallel, so that the force is applied on the whole inside of the connector. When necessary, a support may be inserted in the connecting pipe, to avoid that the connecting pipe is distorted while applying the load.

### 4.4.4 Method

- The test temperature is  $(23 \pm 5) ^\circ\text{C}$ .
- Install the assembly on the testing machine as shown in figure 1.

Figure 1 : assembly of connector and clay pipe

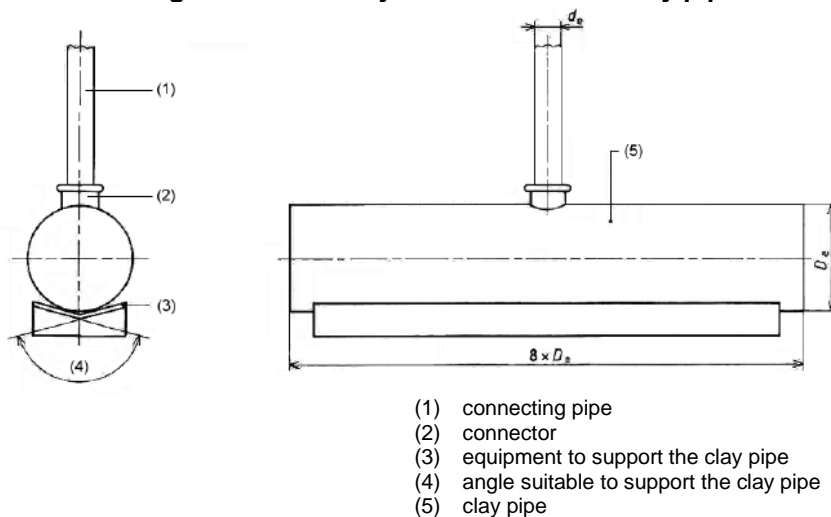

- Apply on the connecting pipe a centric load of  $(40 \pm 2)$  kN. Apply this load with a rate of increase of 0,8 to 1,2 kN/s. Keep the load for  $(5 - 0/+1)$  minutes. After this time, remove the load as smooth as possible within maximum 30 seconds.
- Test the watertightness of the assembly of the clay pipe, the connector and the connecting pipe with a water pressure of  $(1 \pm 0.05)$  bar for a period of  $(15 - 0/+1)$  minutes. Evaluate the result after this 15 minutes, while keeping the water pressure.

---

#### 4.4.5 Result

The assembly is evaluated as watertight when no visual leakage appear between the connector and the clay pipe and between the connector and the connecting pipe.

---

#### 4.4.6 Test report

The test report sets out at least:

- the details of the laboratory,
- the details and identification of the connector and the clay pipe,
- the date of the test,
- reference to his PTV,
- the result of the watertightness of the assembly,

Each test report is supplemented by an assessment of conformity to the requirements.

## 5 PRODUCT IDENTIFICATION

### 5.1 PRODUCT NAME

#### 5.1.1 Official name

The official name has to be in accordance to article 7 of EN 295-4.

#### 5.1.2 Commercial name

The commercial is freely chosen by the supplier in so far as it does not lead to confusion or clash with the official name.

### 5.2 IDENTIFICATION

#### 5.2.1 Delivery modes

5.2.1.1 Adaptors and connectors are delivered in bulk.

5.2.1.2 Joint materials and flexible couplings supplied as separate components are delivered in bulk.

#### 5.2.2 Identification of the products

5.2.2.1 Adaptors and connectors

The following information must be given on each product unit:

- all relevant information as foreseen in EN 295-4, Clause 8;
- reference to PTV 895-1 in case of products in vitrified clay;
- for all other products incorporated in EN 295-4 (Annexes A & B), there has to be reference to this PTV;
- the class for the chemical and physical resistance to effluent (see Clause 3.5.5).

5.2.2.2 Joint materials

5.2.2.2.1 Vulcanized rubber sealing elements

Vulcanized rubber sealing elements which are supplied as separate components, shall be marked with reference to PTV 832-1 and the classification for high chemical resistance.



#### 5.2.2.2.2 Cast polyurethane sealing elements

Identification is not possible. These joint materials are always fixed at an adaptor or a connector.

#### 5.2.2.3 Coupling materials

##### 5.2.2.3.1 Polypropylene sleeve couplings

As according to this PTV, polypropylene sleeve couplings shall meet the requirements of this PTV, they shall be marked with reference to PTV 895-4.

##### 5.2.2.3.2 Metal banded flexible couplings and adaptors

As according to this PTV, metal banded flexible couplings and adaptors shall meet the requirements of this PTV, they shall be marked with reference to PTV 895-4.

##### 5.2.2.3.3 Connectors, insertable fittings and sealing reals

As according to this PTV, connectors, insertable fittings and sealing reals shall meet the requirements of this PTV, they shall be marked with reference to PTV 895-4.

## **6 APPLICATION OF THE PRODUCT (informative)**

### **6.1 APPLICATION OF THE PRODUCT**

#### **6.1.1 Application of a lubricant**

The lubricant is delivered by the dealer of the adaptors and connectors.

#### **6.1.2 Application of a metal banded flexible coupon and adaptor**

Metal banded flexible couplings and adaptors consist of rubber sleeves, with or without rubber bushes, with adjustable stainless steel tension bands by which they are secured to the pipe ends. They can also incorporate shear bands. Adaptors can incorporate an abrupt change of section.

#### **6.1.3 Application of sealing rings**

Sealing rings are for use when pipes with a socket controlled dimensional jointing system are cut to a shorter length, thereby losing their spigot joint fairings and/or sealing elements. They may include an encapsulated steel ring.

#### **6.1.4 Application of couplings and adaptors**

When fitted according to the manufacturer's instructions, couplings and adaptors shall not damage or distort the pipes to which they are connected. All stainless steel parts shall be edge dressed and free from sharp edges.

---